

Effect of Walls on Synchronization of Thermostatic Room-Temperature Oscillations

Mihir Sen

Department of Aerospace and Mechanical Engineering
 University of Notre Dame, Notre Dame, IN 46556, U.S.A.
 Tel.: 575-631-5975, Fax: 575-631-8314
 Mihir.Sen.1@nd.edu

Resumen

El control termostático con histéresis causa oscilaciones de temperatura en cuartos que están calentados o enfriados. Normalmente hay límites superiores e inferiores en temperatura donde el calentador o enfriador deja de funcionar. Modelos sencillos de primer orden con parámetros concentrados pueden predecir el comportamiento dinámico de estos sistemas. Sin embargo, la presencia de paredes adyacentes influye mucho en las oscilaciones de la temperatura en el cuarto. Las paredes almacenan 100 veces más energía interna que el aire, pero es el aire a quien se monitorea ya que este se calienta y/o enfría. En este trabajo se desarrolla un modelo matemático que toma en cuenta la presencia de la pared. El modelo es para un número arbitrario de cuartos en la forma de un anillo. Se muestran soluciones numéricas detalladas para un número pequeño de cuartos con y sin almacenamiento de energía en las paredes. El análisis de perturbación ayuda a entender la física del proceso.

Abstract

Thermostatic control with hysteresis causes temperature fluctuations in rooms that are being heated or cooled. Usually there are upper and lower temperature limits at which the heater or cooler cuts out. Simple first-order lumped parameter models can predict the dynamic behavior of such systems. However, the presence of adjacent walls greatly influences the temperature oscillations in a room. The walls store more than 100 times the internal energy of the air, but it is the air that is monitored and that is heated or cooled. In this work a mathematical model that takes into account the presence of the wall is developed. The model is for an arbitrary number of rooms in the form of a ring. Detailed numerical solutions are shown for a small number of rooms both with and without energy storage in walls. A perturbation analysis helps in understanding the physics of the process.

Palabras clave:

Sincronización, oscilaciones, control termostático.

Keywords:

Synchronization, oscillations, thermostatic control

Nomenclatura

A_{∞}	heat transfer area with exterior
A	heat transfer area between rooms
c	specific heat
h	convective heat transfer coefficient
K	ratio of thermal resistances
m	ratio of heat capacities
M	mass
n	number of rooms
Q	heat rate from heater
t	time
T	temperature
T_{∞}	exterior temperature
U_{∞}	overall heat transfer coefficient with exterior

Greek symbols

ϵ	K/m
$\tau_{1,2}$	times scales

Subscripts and superscripts

a	room air
i	room number
$i \pm 1/2$	wall number
L	lower temperature limit
max	temperatures with heaters always on
U	upper temperature limit
w	wall
*	dimensional quantity

Introduction

The possibility of synchronization of weakly-connected self-excited oscillations has been known for a long time (Pikovsky, A., Rosenblum, M., and Kurths, J., 2001, Strogatz, S., 2003, Manrubia, S., Mikhailov, A., and Zanette, D., 2004). A mechanical example is the synchronization of pendulums supported on the same structure (Bennett, M.,

Schatz, M., Rockwood, H., and Wiesenfeld, K., 2002, Wiesenfeld, K., and Borrero-Echeverry, D., 2011, Li, A., Zeng, J., Yang, H., and Xiao, J., 2011). Very few thermal systems have been investigated in this regard though the possibility certainly exists. Synchronization of temperature oscillations in a thermal-hydraulic network has been experimentally observed (Cai, W., Sen, M., Yang, K., and Mc-Clain, R., 2006). Temperature fluctuations due to heating or cooling in individual rooms of buildings is another example of the thermal problem which may lead to synchronization. These fluctuations are the product not only of external temperature variations, but also of thermal control systems which attempt to regulate room temperatures. It is important to understand these oscillations because of the effect that they have on overall building energy usage.

As a simplified version of a multiple-roomed building we consider a ring of rooms in which each room has a heater that goes *on* or *off* depending on the temperature of the air in that room. Though the cooling problem is very similar, we will assume that there is only heating. A little hysteresis, i.e. a dead band, is built into the thermostat in the form of a difference in temperatures at which the heater goes *on* and that at which it goes *off*.

First-order lumped parameter models have been postulated for the analysis of these temperature oscillations (Cai, W., and Sen, M., 2008, O'Brien, J., and Sen, M., 2011). However, these studies have not taken the presence of walls into account. Though the air temperature determines the comfort level, the walls are the ones that store heat. The walls thus strongly affect the dynamics of thermal energy in buildings, even though it is the air that is being heated. It is thus important to include both air and walls, and to understand the effect of interaction between them.

The objective is to analyze the temperature dynamics in n rooms in the form of a ring as shown in Fig. 1. The dimensional air temperature in room i is $T_i(t^*)$, where t^* is dimensional time, and the dimensional wall temperatures on either side of it are $T_{i-1/2}^*(t^*)$ and $T_{i+1/2}^*(t^*)$. Integer subscripts are used for the air and fractional for the walls on either side.

Of course, being a ring, $i = n + 1$ is the same as $i = 1$, and $i = n + 1/2$ the same as $i = 1/2$. There is convective heat transfer from the air in each room to the walls. There is also heat exchange from the room to the exterior and interior spaces which are both at temperature T_∞ .

Model of n Rooms with Walls

We will use a lumped parameter analysis, and neglect radiation both within the rooms as well as outside. For simplicity, all rooms and walls are taken to be identical. Energy balance for the air in the rooms gives

$$M_a c_a \frac{dT_i^*}{dt^*} = Q_i^* + U_\infty A_\infty (T_\infty - T_i^*) + hA \left(T_{i-1/2}^* - T_i^* \right) + hA \left(T_{i+1/2}^* - T_i^* \right) \tag{1a}$$

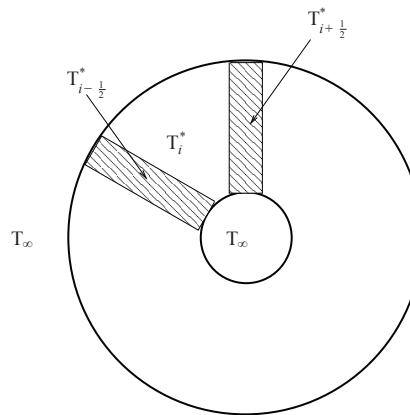

Figure 1. Room with walls.

where M_a is the mass of the air, c_a is the specific heat of air at constant pressure, h and A are the heat transfer coefficient and area for convective heat transfer between the air and the wall, respectively, and U_∞ and A_∞ are the overall heat transfer coefficient and area for heat exchange with T_∞ . The heat input is

$$Q_i^*(t^*) = \begin{cases} Q^* & \text{heater on} \\ 0 & \text{heater off} \end{cases} \tag{1b}$$

Energy balance for the walls gives

$$M_w c_w \frac{dT_{i+1/2}^*}{dt^*} = hA \left(T_i^* - T_{i+1/2}^* \right) + hA \left(T_{i+1}^* - T_{i+1/2}^* \right) \tag{1c}$$

The unknowns in Eqs. (1) are $T_i^*(t^*)$, $T_{i+1/2}^*(t^*)$, and $Q_i^*(t^*)$ for $i = 1, 2, \dots, n$, with initial conditions $T_i^*(0)$, $T_{i+1/2}^*(0)$, and $Q_i^*(0)$. It must be emphasized that the equations are nonlinear because the instants at which the heating switches from *on* to *off*, or vice versa, are not a priori known but depend on $T_i^*(t^*)$.

The limits of operation of the thermostats must also be prescribed. They have an upper limit T_U^* at which they switch *off*, and a lower limit T_L^* at which they come *on*.

If the heater is kept always on, the final steady state temperatures of both wall and air, $T_{i,max}^*$ and $T_{i+1/2,max}^*$, respectively, given by Eq. (1) will be

$$T_{i,max}^* = T_{i+1/2,max}^* = \frac{Q}{U_\infty A_\infty} + T_\infty \tag{2}$$

Nondimensional equations

To nondimensionalize Eqs. (1), the following independent and dependent variables

$$t = \frac{U_\infty A_\infty}{M_a c_a} t^*, \tag{3a}$$

$$T_i = \frac{U_\infty A_\infty}{Q} (T_i^* - T_\infty), \quad (3b)$$

$$Q_i = \frac{Q_i^*}{Q}, \quad (3c)$$

are used. The governing equations become

$$\frac{dT_i}{dt} = Q_i - T_i + K \left(T_{i-\frac{1}{2}} - T_i \right) + K \left(T_{i+\frac{1}{2}} - T_i \right), \quad (4a)$$

$$Q_i = \begin{cases} 1 & \text{heater on} \\ 0 & \text{heater off} \end{cases}, \quad (4b)$$

$$m \frac{dT_{i+\frac{1}{2}}}{dt} = K \left(T_i - T_{i+\frac{1}{2}} \right) + K \left(T_{i+1} - T_{i+\frac{1}{2}} \right), \quad (4c)$$

with given initial conditions $T_i(0)$, $T_{i-\frac{1}{2}}(0)$, and $Q_i(0)$, where

$$K = \frac{hA}{U_\infty A_\infty}, \quad (5a)$$

$$m = \frac{M_w c_w}{M_a c_a}. \quad (5b)$$

Parameters

The parameter K represents the ratio of the thermal resistance between the air in the room and the outside to that between the air and the walls. The value depends greatly on the geometry of the design, the materials used, and the prevailing wind and atmospheric conditions. Nonetheless, one has to have some idea for the value of K to search for solutions in that range. Of the two areas, A may be much larger than A_∞ , or may be of comparable size. The convective heat transfer coefficient h is generally small because it is mostly due to natural convection. U_∞ is affected by insulation in the outer walls which tends to reduce its value, and by the winds blowing on the exterior which will increase it.

The other parameter m is the ratio of the heat capacity of a wall compared to that of the air in the room. This is the parameter that controls the effect of the wall on the room temperature, and it is usually large.

To get an idea of the numerical values of the parameters, let the volume of air = 27 m³ per room, the mass of each wall = 6210 kg. We also take $A = 9 \text{ m}^2$, $A_\infty = 24 \text{ m}^2$, and $c_w = 0.75 \text{ kJ/kg}\cdot\text{K}$. This gives $m = 142.4$. The two heat transfer coefficients, one internal and the other external, are much more problematic (Longstaff, R., and Finnigan, J., 1983, Hagishima, A., and Tanimoto, J., 2003, Hagishima, A., Tanimoto, J., and Narita, K., 2005, Emmel, M., Abadie, M., and Mendes, N., 2007, Palyvos, J., 2008, Shao, J., Liu, J., Zhao, J., Zhang, W., Sun, D., and Fu, Z., 2009, Defraeye, T., Blocken, B., and Carmeliet, J., 2011, Luo, C., Moghtaderi, B., Hands, S., and

Page, A., 2011). There are some values available in the literature for this, but the numbers obviously depend strongly on airflow conditions. If we take $h = 5 \text{ W/m}^2\cdot\text{K}$, $U_\infty = 10 \text{ W/m}^2\cdot\text{K}$, we get $K = 0.188$. The value of K is important since the appearance of in-phase and out-of-phase synchronization is sensitive to it. For the present, however, fixed values of $K = 0.1$ and $m = 100$, which are reasonable, will be taken.

The heat rate Q^* is another parameter that must be chosen. Assuming that the heater, if it is always *on*, can produce maximum air and wall temperatures of $T_{i,max}^* = T_{i+\frac{1}{2},max}^* = (40 + T)^\circ\text{C}$, then $Q^* = 9.6 \text{ kW}$. If we take $T_U^* = (17.6 + T_\infty)^\circ\text{C}$ and $T_L^* = (8.8 + T_\infty)^\circ\text{C}$, then their non-dimensional counterparts are $T_U = 0.44$ and $T_L = 0.22$, which are the values chosen in this study.

Initial conditions will be taken to be T_L for all the rooms as well as the walls, and the heater is initially assumed to be on.

Specific Configurations

The problem of an arbitrary number of rooms is difficult to solve and analyze due to the nonlinearities and large number of parameters involved, so we will begin with a small number of rooms.

Single room, $n = 1$

Though this is not a ring, as shown in Fig. 2, it is a simple configuration which yields valuable information to which the other solutions can be compared.

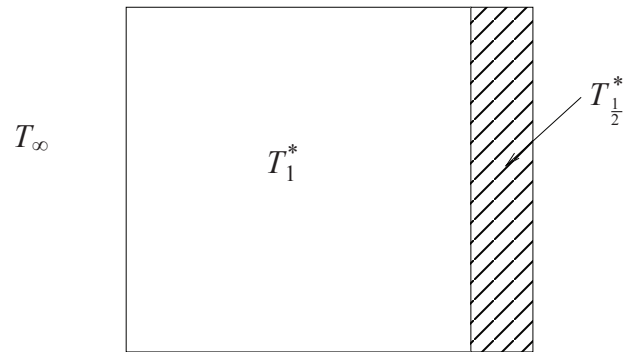

Figure 2: Single room with wall.

Here, Eqns. (4) become

$$\frac{dT_1}{dt} = Q_1 - T_1 + K \left(T_{\frac{1}{2}} - T_1 \right), \quad (6a)$$

$$m \frac{dT_{\frac{1}{2}}}{dt} = K \left(T_1 - T_{\frac{1}{2}} \right). \quad (6b)$$

The solution of Eq. (6b) is

$$T_{\frac{1}{2}} = e^{-Kt/m} \left(\frac{K}{m} \int_0^t e^{Kt'/m} T_1(t') dt' + C \right). \quad (7)$$

Substituting in Eq. (6a) gives

$$\frac{dT_1}{dt} + (1+K)T_1 = Q_1 + e^{-Kt/m} \left(\frac{K}{m} \int_0^t e^{Kt'/m} T_1(t') dt' + C \right), \quad (8)$$

which upon differentiation is equivalent to

$$\frac{d^2T_1}{dt^2} + \left(1+K + \frac{K}{m} \right) \frac{dT_1}{dt} + \frac{K}{m} T_1 = \frac{K}{m} Q_1. \quad (9)$$

The solution for values of K and m in the range we are considering is

$$T_1 = Ae^{-t/\tau_1} + Be^{-t/\tau_2} \quad (10)$$

where

$$\tau_{1,2} = 2 \left[\left(1+K + \frac{K}{m} \right) \pm \sqrt{\left(1+K + \frac{K}{m} \right)^2 - 4 \frac{K}{m}} \right]^{-1} \quad (11)$$

There are two time scales τ_1 and τ_2 .

Two rooms, $n = 2$

This is shown in Fig. 3. Eqns. (4) are

$$\frac{dT_1}{dt} = Q_1 - T_1 + K \left(T_{\frac{1}{2}} - T_1 \right) + K \left(T_{\frac{1+\frac{1}{2}}{2}} - T_1 \right), \quad (12a)$$

$$\frac{dT_2}{dt} = Q_2 - T_2 + K \left(T_{\frac{1+\frac{1}{2}}{2}} - T_2 \right) + K \left(T_{\frac{1}{2}} - T_2 \right), \quad (12b)$$

$$m \frac{dT_{\frac{1}{2}}}{dt} = K \left(T_1 - T_{\frac{1}{2}} \right) + K \left(T_2 - T_{\frac{1}{2}} \right), \quad (12c)$$

$$m \frac{dT_{\frac{1+\frac{1}{2}}{2}}}{dt} = K \left(T_1 - T_{\frac{1+\frac{1}{2}}{2}} \right) + K \left(T_2 - T_{\frac{1+\frac{1}{2}}{2}} \right), \quad (12d)$$

Three rooms, $n = 3$

Three rooms are shown in Fig. 4. The equations are similar to Eq. (12) above, but with a third room and wall added.

Limiting Analyses

No energy storage in walls, $m = 0$

This is equivalent to ignoring the energy storage capacity of the wall. For $n = 1$, Eqs. (6) give

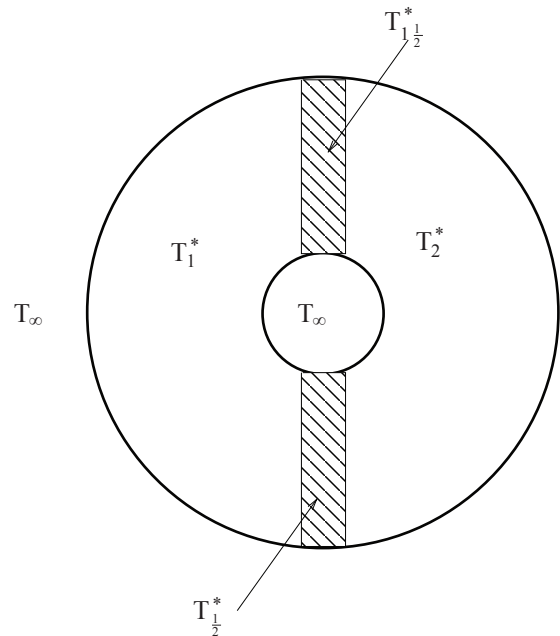

Figure 3: Two-room configuration with separating walls.

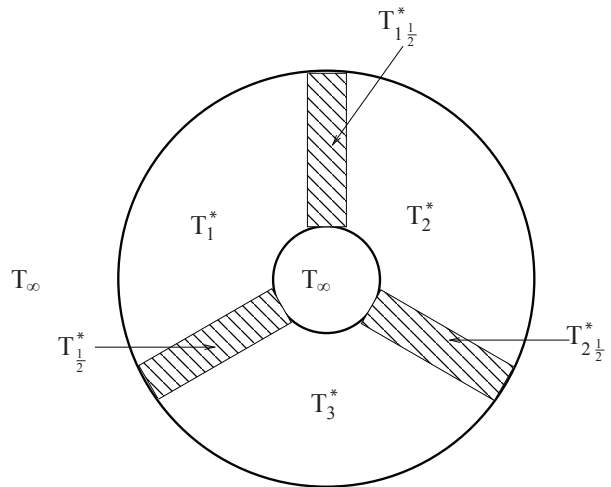

Figure 4: Three-room configuration with separating walls.

$$T_1 = T_{\frac{1}{2}}, \quad (13)$$

$$\frac{dT_1}{dt} = Q_1 - T_1. \quad (14)$$

Fig. 5 shows the temperature and Fig. 6 the heat rate. The time constant of the first-order system is unity.

These graphs and those that follow are generated using an explicit Euler method with a step size in time of 0.001. Integration is performed up to 50,000 time steps, but only the last 5 time units are shown. This is done to enable the tran-

sients in the system to die out. The steady-state dynamics of the system is strongly dependent on the system parameters and initial conditions chosen. At this stage a comprehensive study of all possibilities has not been carried out. In the following graphs the values of the parameters and initial conditions are the same as mentioned before, except in Fig. 9 where the values are different and indicated in its caption.

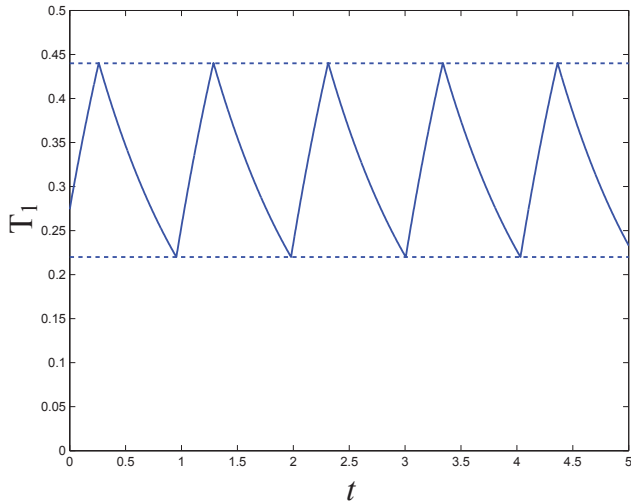

Figure 5: Temperature of single room without energy storage in wall. Dashed lines are lower and upper temperature bounds of thermostat.

For $n = 2$, Eqns. (12) give

$$T_{\frac{1}{2}} = T_{\frac{1}{2}} = \frac{1}{2}(T_1 + T_2), \tag{15a}$$

$$\frac{dT_1}{dt} = Q_1 - T_1 + K(T_2 - T_1), \tag{15b}$$

$$\frac{dT_2}{dt} = Q_2 - T_2 + K(T_1 - T_2), \tag{15c}$$

The temperature-time responses for $n = 2$ are shown in Fig. 7, and for $n = 3$ in Fig. 8.

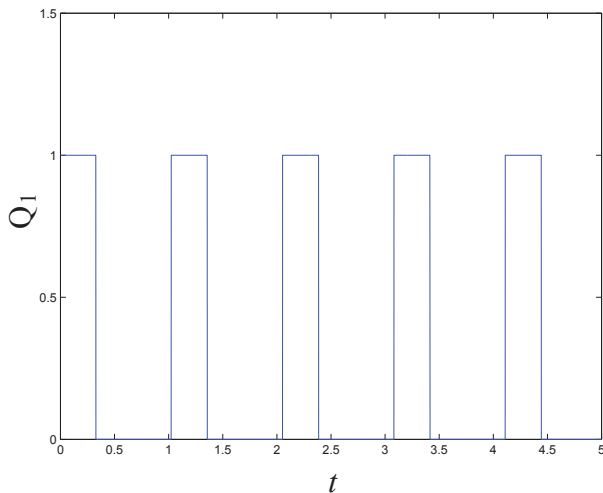

Figure 6: Heat rate in single room without energy storage in wall.

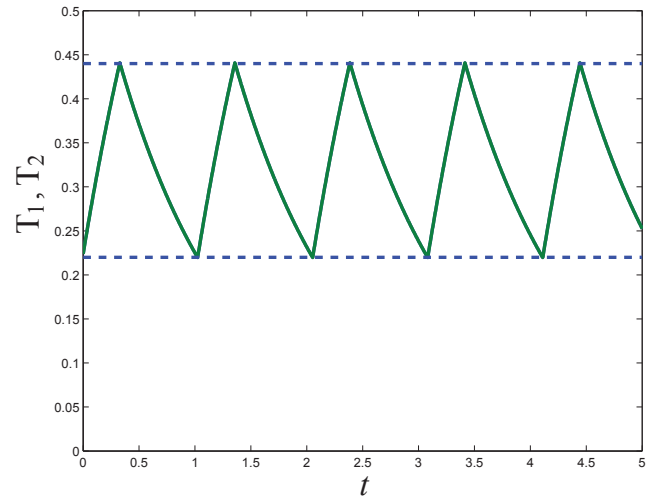

Figure 7: Temperatures of two rooms without energy storage in walls.

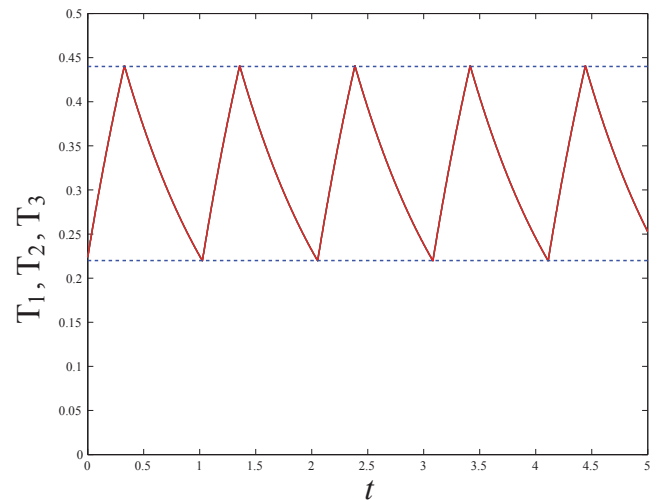

Figure 8: Temperatures of three rooms without energy storage in walls.

So far only in-phase synchronization has been shown. Fig. (9) shows a situation in which an out-of-phase synchronization appears. Note that all the parameter values are the same as before, except those indicated in the caption.

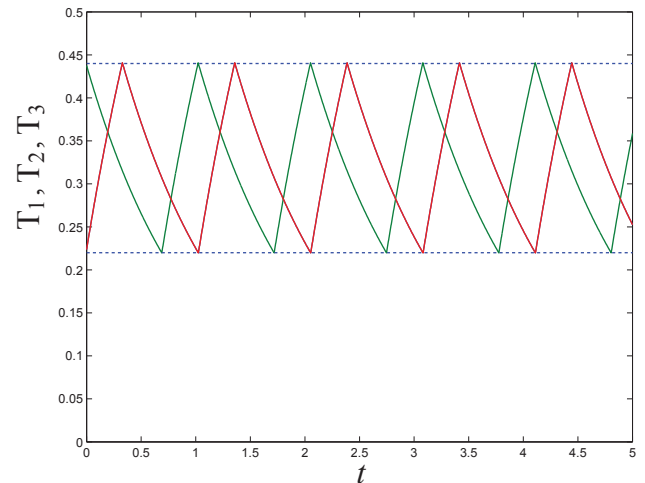

Figure 9: Temperatures of three rooms without energy storage in walls; $K = 0.001$ with $T_2(0) = T_U$, $Q_2(0) = 0$.

Infinitely massive walls, $m \rightarrow \infty$

For this, Eq. (4c) shows that

$$\frac{dT_{i+\frac{1}{2}}}{dt} = 0. \tag{16}$$

The walls are so massive that their temperatures remain constant with time, equal to the initial values $T_{i+\frac{1}{2}}(0)$. Eq. (4a) then shows that

$$\begin{aligned} \frac{dT_i}{dt} = & Q_i - (1 + 2K)T_i \\ & + K \left(T_{i-\frac{1}{2}}(0) + T_{i+\frac{1}{2}}(0) \right). \end{aligned} \tag{17}$$

The last term in this equation is a constant, and the problem, even with multiple rooms, is then equivalent to that for a single room without a wall. The dynamics of the rooms are decoupled. Note also that the time constant of the first-order system is $1/(1 + 2K)$.

No heat exchange with wall, $K = 0$

For this

$$\frac{dT_i}{dt} = Q_i - T_i, \tag{18a}$$

$$\frac{dT_{i+\frac{1}{2}}}{dt} = 0. \tag{18b}$$

This is essentially the same as taking $m = 0$ discussed previously. The air temperature equation is the same while the wall temperature is constant in time.

Dynamics with Energy Storage in Walls

In reality, m is neither zero nor infinity, and the dynamics has to be calculated numerically. Solutions for a single room with a wall are shown in Fig. 10. Fig. 11 shows $(T_{\frac{1}{2}} - 0.3229)$ in an expanded scale to be able to appreciate the small amplitude temperature oscillations in the wall, being about 0.01 % of those in the air. Fig. 12 shows the temperature fluctuations for two rooms, and Fig. 13 for three rooms.

Perturbation Analysis

To simplify the analysis, we will assume that $\epsilon = K/m \ll 1$. The perturbation is regular, so that

$$T_i = T_i^0 + \epsilon T_i^1 + \epsilon^2 T_i^2 + \dots \tag{19}$$

$$T_{i+\frac{1}{2}} = T_{i+\frac{1}{2}}^0 + \epsilon T_{i+\frac{1}{2}}^1 + \epsilon^2 T_{i+\frac{1}{2}}^2 + \dots \tag{20}$$

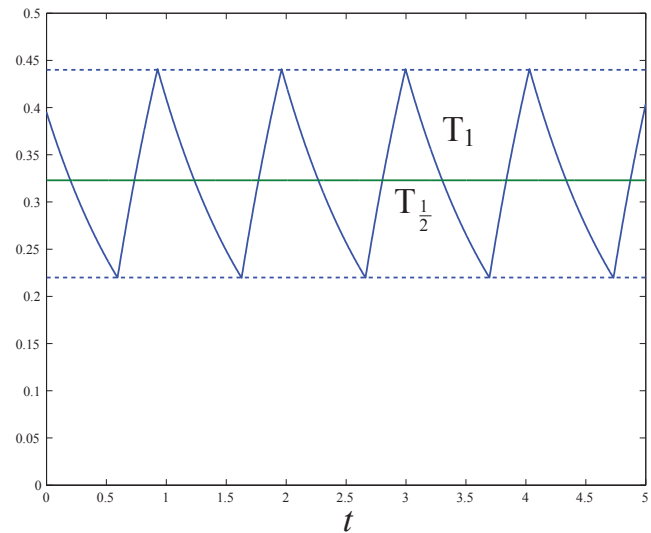

Figure 10: Single room with energy storage in wall: air and wall temperatures.

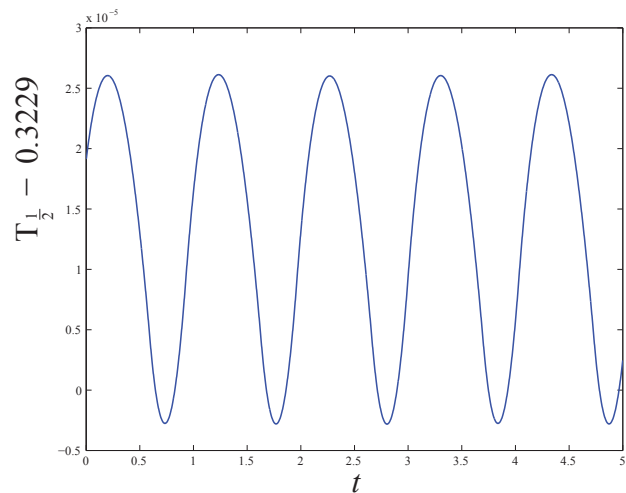

Figure 11: Single room with energy storage in wall: wall temperature.

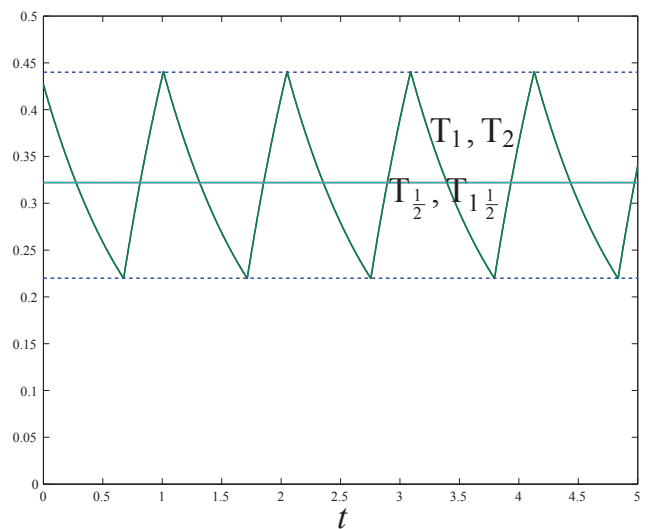

Figure 12: Two rooms with energy storage in walls: air and wall temperatures.

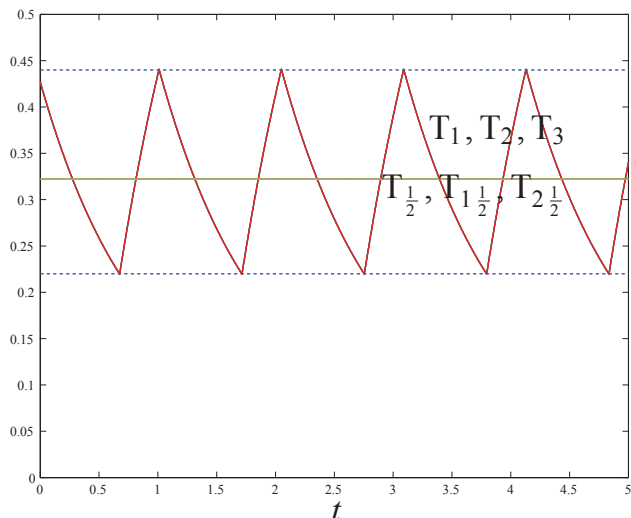

Figure 13: Three rooms with energy storage in walls: air and wall temperatures.

Thus, to lowest order

$$\frac{dT_i^0}{dt} = Q_i - T_i^0 + K \left(T_{i-\frac{1}{2}}^0 - T_i^0 \right) \quad (21a)$$

$$K \left(T_{i+\frac{1}{2}}^0 - T_i^0 \right),$$

$$\frac{dT_{i+\frac{1}{2}}^0}{dt} = 0. \quad (21b)$$

The wall temperatures, $T_{i+\frac{1}{2}}^0 = T_{i+\frac{1}{2}}^0(0)$, are constant. Eq. (21a) is similar to that studied previously where $m = 0$. Thus the lowest order solutions are as if they were without energy storage in walls. The time constant is $1/(1 + 2K)$.

To the next order the time scales from Eqs. (11) are

$$\tau_1 = \frac{1+K}{K} \frac{1}{\epsilon} \quad (22a)$$

$$\tau_2 = \frac{1}{1+K} \quad (22b)$$

The ratio of the two is large, so this problem is stiff. The second time scale is the same one obtained from Eqs. (6) with $K=0$ and $T_{i+\frac{1}{2}}$ constant. So the first one, which is large, is due to the presence of the wall.

Conclusions

Though human comfort is felt through the air, thermal energy storage is in the walls. Roughly 100 times the energy in the air is stored in the walls. The massiveness of the walls serves to damp out the temperature oscillations in the air as well as introduce a large time scale. Thus a slow and small-

amplitude modulation is introduced into the temperature dynamics by the walls. The nature of the solution depends on a large number of parameters: initial conditions, low and high temperature cutoffs for the thermostat, and parameters K and m . Some of these will lead to in-phase synchronization, as in Fig. 8, and others to out-of-phase, as Fig. 9. This was not studied here in any detail. The stiffness of the governing equations is a primary obstacle to an easy numerical solution of the problem. Nonlinearity is a second impediment. To a lesser degree, the third is the number of parameters and initial conditions that must be specified. Even for the same set of parameters, different initial conditions may lead to different long time behaviors. Of practical interest are the bifurcations that exist as a parameter such as m or K is changed through a wide range of values. This co-existence of attractors is an interesting phenomenon that will be investigated in future work.

References

- Pikovsky, A., Rosenblum, M., and Kurths, J., 2001. *Universal Concept in Nonlinear Sciences*. Cambridge University Press, Cambridge.
- Strogatz, S., 2003. *Sync: The Emerging Science of Spontaneous Order*. Theia, New York.
- Manrubia, S., Mikhailov, A., and Zanette, D., 2004. *Emergence of Dynamical Order: Synchronization Phenomena in Complex Systems*. World Scientific, New Jersey.
- Bennett, M., Schatz, M., Rockwood, H., and Wiesenfeld, K., 2002. "Huygens's clocks". *Proceedings of the Royal Society, Series A, Mathematical, Physical and Engineering Sciences*, 458(2019), pp. 563–579.
- Wiesenfeld, K., and Borrero-Echeverry, D., Art. No. 047515, 2011. "Huygens (and others) revisited". *Chaos*, 21(4).
- Li, A., Zeng, J., Yang, H., and Xiao, J., 2011. "A laboratory experiment on coupled non-identical pendulums". *European Journal of Physics*, 32(5), pp. 1251–1257.
- Cai, W., Sen, M., Yang, K., and Mc-Clain, R., 2006. "Synchronization of self-sustained thermostatic oscillations in a thermal-hydraulic network". *International Journal of Heat and Mass Transfer*, 49(23-24), pp. 4444–4453.
- Cai, W., and Sen, M., 2008. "Synchronization of thermostatically controlled first-order systems". *International Journal of Heat and Mass transfer*, 51(11-12), pp. 3032–3043.
- O'Brien, J., and Sen, M., IMECE2011-63153, 2011. "Temperature synchronization, phase dynamics and oscillation death in a ring of thermally-coupled rooms". In *Proceedings of the International Mechanical Engineering Congress and Exposition (IMECE)*, Nov. 11-17, 2011, Denver, CO, U.S.A.

Longstaff, R., and Finnigan, J., 1983. "A wind-tunnel model study of forced convective heat-transfer from a horizontal grain storage shed". *Journal of Stored Products Research*, 19(2), pp. 81–87.

Hagishima, A., and Tanimoto, J., 2003. "*Field measurements for estimating the convective heat transfer coefficient at building surfaces*". *Building and Environment*, 38(7), pp. 873–881.

Hagishima, A., Tanimoto, J., and Narita, K., 2005. "*Intercomparisons of experimental convective heat transfer coefficients and mass transfer coefficients of urban surfaces*". *Boundary-Layer Meteorology*, 117(3), pp. 551–576.

Emmel, M., Abadie, M., and Mendes, N., 2007. "*New external convective heat transfer coefficient correlations for isolated low-rise buildings*". *Energy and Buildings*, 39(3), pp. 335–342.

Palyvos, J., 2008. "A survey of wind convection coefficient correlations for building envelope energy systems' modeling". *Applied Thermal Engineering*, 28(8-9), pp. 801–808.

Shao, J., Liu, J., Zhao, J., Zhang, W., Sun, D., and Fu, Z., 2009. "A novel method for full-scale measurement of the external convective heat transfer coefficient for building horizontal roof". *Energy and Buildings*, 41(8), pp. 840–847.

Defraeye, T., Blocken, B., and Carmeliet, J., 2011. "*Convective heat transfer coefficients for exterior building surfaces: Existing correlations and CFD modelling*". *Energy Conversion and Management*, 52(1), pp. 512–522.

Luo, C., Moghtaderi, B., Hands, S., and Page, A., 2011. "*Determining the thermal capacitance, conductivity and the convective heat transfer coefficient of a brick wall by annually monitored temperatures and total heat fluxes*". *Energy and Buildings*, 43(2-3), pp. 379–385.